

Write your name here

Surname

Other names

Pearson
Edexcel GCE

Centre Number

--	--	--	--	--	--

Candidate Number

--	--	--	--	--	--

Physics

Advanced

Unit 4: Physics on the Move

Monday 20 June 2016 – Morning

Time: 1 hour 35 minutes

Paper Reference

6PH04/01

You do not need any other materials.

Total Marks

Instructions

- Use **black** ink or ball-point pen.
- **Fill in the boxes** at the top of this page with your name, centre number and candidate number.
- Answer **all** questions.
- Answer the questions in the spaces provided
– *there may be more space than you need.*

Information

- The total mark for this paper is 80.
- The marks for **each** question are shown in brackets
– *use this as a guide as to how much time to spend on each question.*
- Questions labelled with an **asterisk** (*) are ones where the quality of your written communication will be assessed
– *you should take particular care with your spelling, punctuation and grammar, as well as the clarity of expression, on these questions.*
- The list of data, formulae and relationships is printed at the end of this booklet.
- Candidates may use a scientific calculator.

Advice

- Read each question carefully before you start to answer it.
- Keep an eye on the time.
- Try to answer every question.
- Check your answers if you have time at the end.

Turn over ►

P46648A

©2016 Pearson Education Ltd.

1/1/1/1/



PEARSON

SECTION A

Answer ALL questions.

For questions 1–10, in Section A, select one answer from A to D and put a cross in the box . If you change your mind, put a line through the box and then mark your new answer with a cross .

- 1 Particles may be accelerated in a cyclotron.
Which of the following statements is true for a cyclotron?
- A Particles travel in a circular path of constant radius.
 - B Protons and neutrons can be accelerated in a cyclotron.
 - C Particles can be accelerated to speeds up to $3.2 \times 10^8 \text{ m s}^{-1}$.
 - D A magnetic field is used to keep particles moving in a circular path.

(Total for Question 1 = 1 mark)

- 2 Hadrons can be classified into mesons and baryons.
Which of the following statements is true?
- A Mesons always consist of three quarks.
 - B Mesons always include a quark and an antiquark.
 - C Mesons are formed during beta decay.
 - D Neutrons and protons are examples of mesons.

(Total for Question 2 = 1 mark)

- 3 Which of the following is **not** a unit of mass?
- A u
 - B MeV
 - C MeV/c²
 - D N m⁻¹ s²

(Total for Question 3 = 1 mark)

DO NOT WRITE IN THIS AREA

DO NOT WRITE IN THIS AREA

DO NOT WRITE IN THIS AREA



DO NOT WRITE IN THIS AREA

DO NOT WRITE IN THIS AREA

DO NOT WRITE IN THIS AREA

4 A capacitor is connected to a 6.0 V battery. The charge on the capacitor is 42 pC. What is the energy stored by the capacitor?

- A 1.3×10^{-10} J
- B 2.5×10^{-10} J
- C 1.3×10^{-7} J
- D 2.5×10^{-7} J

(Total for Question 4 = 1 mark)

5 A capacitor with an initial charge Q_0 is discharging through a resistor. The time constant of the circuit is the time for the charge to fall to

- A $0.25 Q_0$
- B $0.37 Q_0$
- C $0.50 Q_0$
- D $0.63 Q_0$

(Total for Question 5 = 1 mark)

6 A loop of wire is placed inside a magnetic field of magnetic flux density 0.30 T as shown.

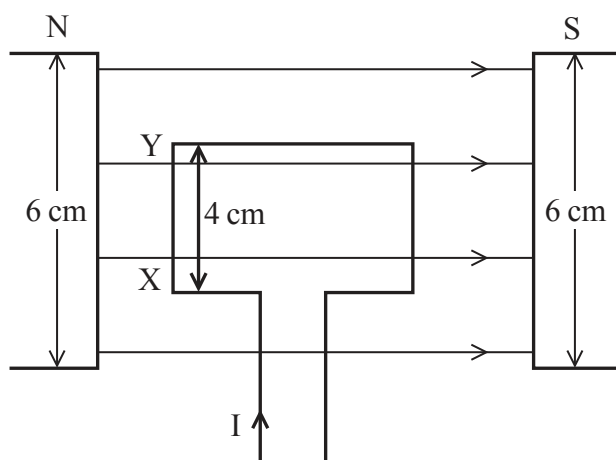

Which of the following is the force on side XY if the current in the wire is 2.0 A?

- A 0.024 N
- B 0.036 N
- C 2.4 N
- D 3.6 N

(Total for Question 6 = 1 mark)



- 7 A student throws a ball horizontally. The graph shows how the force from the student's hand on the ball varies with time during the throw.

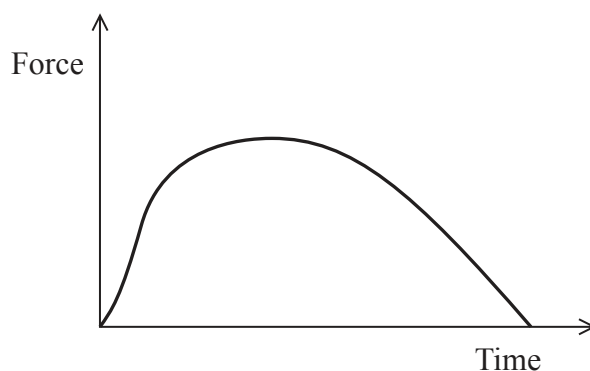

Which of the following quantities is given by the area under the graph?

- A acceleration
- B change in momentum
- C change in velocity
- D rate of change of momentum

(Total for Question 7 = 1 mark)

- 8 The table shows the charge on some quarks.

Quark	Charge / e
u	$+ 2/3$
d	$- 1/3$

Which of the following is a possible quark composition of a π^- particle?

- A dd
- B uu
- C $d\bar{u}$
- D $\bar{d}u$

(Total for Question 8 = 1 mark)



- 9 Two spheres carry equal charges uniformly spread over their surfaces. They are close to each other but not touching.

Each sphere experiences an electrostatic force F .

This force could be reduced to $\frac{1}{2}F$ by

- A doubling the distance between the surfaces of the spheres.
- B doubling the distance between the centres of the spheres.
- C halving the charge on both spheres.
- D halving the charge on one of the spheres.

(Total for Question 9 = 1 mark)

- 10 Particle A of mass m has kinetic energy E_k . Particle B of mass $3m$ has kinetic energy $2E_k$. The ratio of the momentum of particle A to the momentum of particle B is given by

- A $\frac{1}{6}$
- B $\frac{1}{\sqrt{6}}$
- C $\sqrt{6}$
- D 6

(Total for Question 10 = 1 mark)

TOTAL FOR SECTION A = 10 MARKS



SECTION B

Answer ALL questions in the spaces provided.

- 11 Crystal structure can be investigated using the diffraction of an electron beam. A typical diffraction pattern is shown.

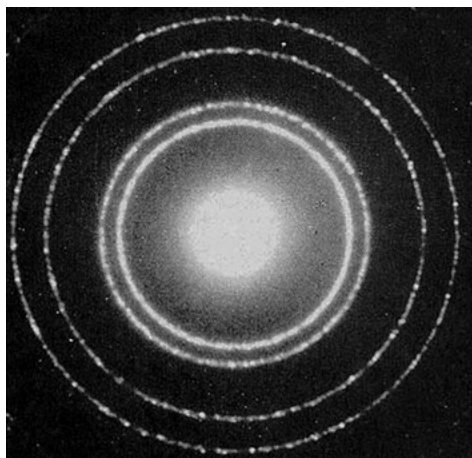

In a particular investigation the atomic spacing of the crystal is 2.3×10^{-11} m and the electrons are accelerated through 3000 V.

- (a) Calculate the wavelength of these electrons.

(3)

.....
.....
.....
.....
.....

Wavelength = m

- (b) State with a reason whether these electrons will produce a suitable diffraction pattern.

(1)

.....
.....

(Total for Question 11 = 4 marks)

DO NOT WRITE IN THIS AREA

DO NOT WRITE IN THIS AREA

DO NOT WRITE IN THIS AREA



DO NOT WRITE IN THIS AREA

DO NOT WRITE IN THIS AREA

DO NOT WRITE IN THIS AREA

12 The picture shows the tracks in a bubble chamber after an interaction. A photon enters from the left and collides with a stationary neutral hydrogen atom. An electron is ejected from the hydrogen atom and moves at high speed. An electron-positron pair is also created.

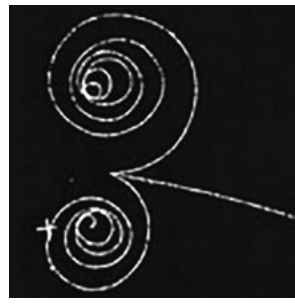

(a) State why the photon leaves no track. (1)

.....

.....

(b) Explain why the ejected electron undergoes less deflection than the electron-positron pair. (2)

.....

.....

.....

.....

(c) Show that charge is conserved in the interaction. (2)

.....

.....

(d) Explain why there is no track from the ionised hydrogen atom after the collision. (2)

.....

.....

.....

(Total for Question 12 = 7 marks)



- 13 During the manufacture of some computer components it is necessary to monitor the position of pieces of silicon.

Capacitors can be used to detect a change in the position of a piece of silicon. The piece of silicon forms one plate of a capacitor whilst a probe acts as the other plate as shown in the diagram.

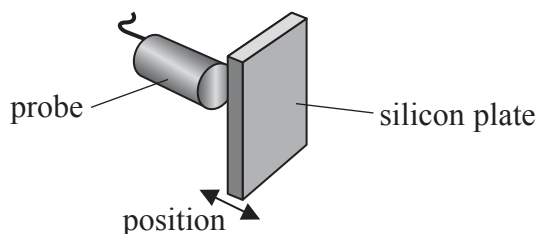

The capacitor is charged by connecting it to a 6.0 V battery as shown in the diagram below.

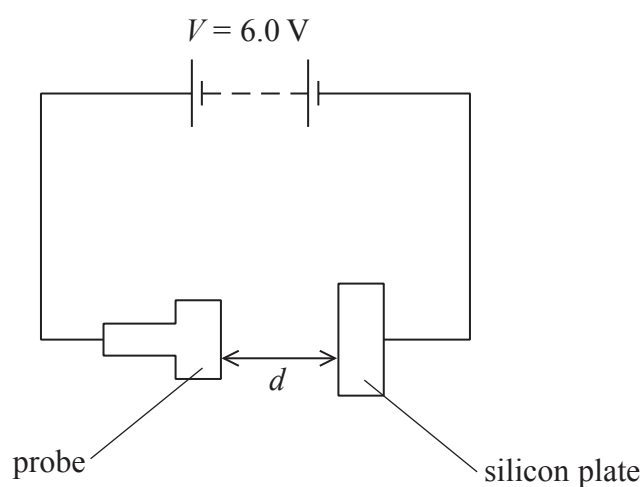

The relationship between the capacitance C and the distance d between the silicon plate and the probe is

$$C = k/d$$

where k is a constant.

- (a) Explain qualitatively how the charge on the capacitor will vary if the silicon plate moves away from the probe.

(2)



DO NOT WRITE IN THIS AREA

DO NOT WRITE IN THIS AREA

DO NOT WRITE IN THIS AREA

(b) When the silicon is in a certain position, the probe is 3.5 mm from it. The silicon must remain within 0.70 mm of this position.

Determine the maximum allowable percentage decrease in the charge on the capacitor.

$$k = 2.8 \times 10^{-15} \text{ F m} \tag{4}$$

.....

.....

.....

.....

.....

.....

.....

.....

.....

.....

Maximum allowable percentage decrease =

(c) In order to detect rapid changes in the position of the silicon, it is necessary to use a capacitor with a small capacitance.

Explain why. (2)

.....

.....

.....

.....

(Total for Question 13 = 8 marks)



- 14 The law of conservation of momentum can be investigated using a low-friction track with two gliders. Glider B is stationary. Glider A is given a gentle push towards glider B. The gliders collide, stick together and move off.

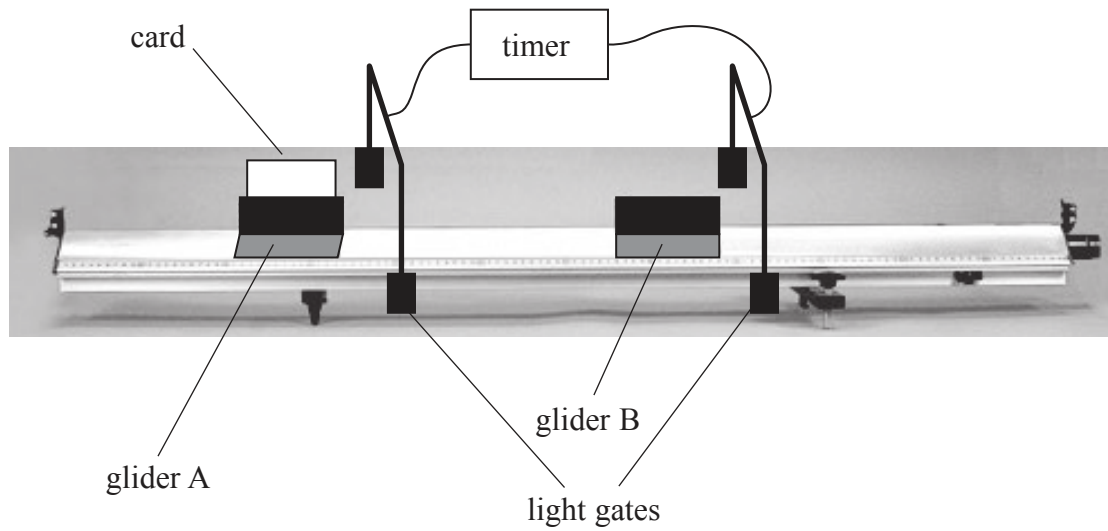

- (a)*⁽ⁱ⁾ Describe how you would use the apparatus shown to verify the law of conservation of momentum.

(5)

.....

.....

.....

.....

.....

.....

.....

.....

.....



DO NOT WRITE IN THIS AREA

DO NOT WRITE IN THIS AREA

DO NOT WRITE IN THIS AREA

(ii) Explain why it is necessary to use a low-friction track to verify the law of conservation of momentum.

(2)

(b) In a different investigation a glider of mass 0.50 kg travelling at 0.90 m s^{-1} collides head-on with a stationary glider of mass 0.70 kg. The 0.50 kg glider continues moving in the same direction at a velocity of 0.20 m s^{-1} . The gliders do not stick together.

(i) Calculate the velocity of the 0.70 kg glider after the collision.

(2)

Velocity =

(ii) By doing further calculations, determine whether the collision is elastic.

(2)

(Total for Question 14 = 11 marks)

DO NOT WRITE IN THIS AREA

DO NOT WRITE IN THIS AREA

DO NOT WRITE IN THIS AREA



15 Faraday's and Lenz's laws of electromagnetic induction state that

$$\varepsilon = -\frac{d(N\Phi)}{dt}$$

(a) (i) State the meaning of the term $N\Phi$ and give its unit.

(2)

(ii) State the significance of the negative sign.

(1)

(b) A student sets up the apparatus shown.

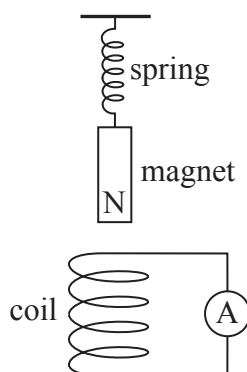

The magnet is pulled down until its north pole is just at the top end of the coil. The magnet is released and initially accelerates upwards away from the coil.

DO NOT WRITE IN THIS AREA

DO NOT WRITE IN THIS AREA

DO NOT WRITE IN THIS AREA



***(i)** With reference to the laws of electromagnetic induction explain why a current is produced in the coil as the magnet moves upwards.

(3)

(ii) Explain why the magnitude of the current varies as the magnet moves upwards.

(2)

(iii) Suggest an advantage of replacing the ammeter with a data logger.

(1)

(Total for Question 15 = 9 marks)

DO NOT WRITE IN THIS AREA

DO NOT WRITE IN THIS AREA

DO NOT WRITE IN THIS AREA



16 (a) A speedometer can be fitted to a bicycle. A magnet is attached to a spoke on one wheel. The magnet passes a sensor once during each revolution of the wheel and an e.m.f. is generated across the sensor. This produces pulses of e.m.f. as the wheel turns. The radius of the wheel and the time between the pulses are used to determine the speed of the bicycle.

- (i) The radius of the bicycle wheel including the inflated tyre is 0.40 m.
Calculate the speed of the bicycle if the magnet passes through the sensor once every 1.2 s.

(2)

Speed =

- (ii) Explain how the reading on the speedometer is affected if the tyre is **not** fully inflated.

(2)

- (iii) In normal use there is a small current in the sensor. When the magnet passes the sensor the magnetic field is perpendicular to the velocity of the electrons. There is a magnetic force on the electrons.

Calculate the magnitude of the magnetic force on an electron moving at $7.4 \times 10^{-4} \text{ m s}^{-1}$.

magnetic flux density = 0.050 T

(2)

Magnetic force =



DO NOT WRITE IN THIS AREA

DO NOT WRITE IN THIS AREA

DO NOT WRITE IN THIS AREA

(b) A cyclist leans to one side as he travels around a bend as shown.



The cyclist is travelling at 9.0 m s^{-1} and leans at an angle of 22° to the vertical. A simplified free-body force diagram for the cyclist and the bicycle is shown below.

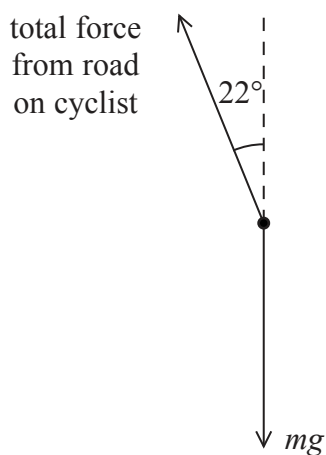

Determine the radius of the bend.

combined mass of cyclist and bicycle = 80 kg

(3)

Radius =

(Total for Question 16 = 9 marks)



P 4 6 6 4 8 A 0 1 5 2 8

- 17 The diagram shows a simplified version of the apparatus used in an experiment to determine the charge on an electron.

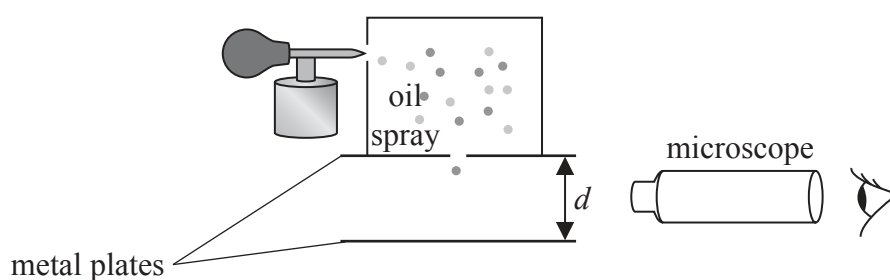

Negatively charged oil drops are sprayed into a region above two parallel metal plates. The plates are separated by a distance d . The oil drops are allowed to enter the region between the two plates.

A potential difference V is applied which causes an electric field to be set up between the plates.

- (a) The diagram shows one oil drop falling between the plates.

Add lines to the diagram to show the electric field between the plates.

(2)

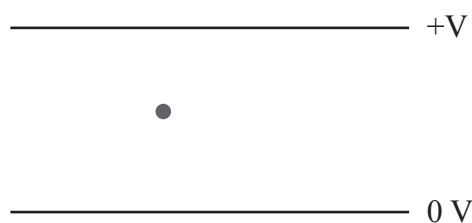

- (b) V is gradually increased. At a particular value of V , the oil drop stops falling and remains stationary between the plates.

Explain this observation.

(2)



DO NOT WRITE IN THIS AREA

DO NOT WRITE IN THIS AREA

DO NOT WRITE IN THIS AREA

(c) The oil drop has mass m and charge Q and stops falling when $V = 5000$ V.

Show that $\frac{Q}{m}$ for this oil drop is about $50 \mu\text{C kg}^{-1}$.

$d = 2.5$ cm

(3)

.....

.....

.....

.....

.....

.....

(d) The oil drop is close to another oil drop that has the same charge and mass. The oil drops can be considered to act as point charges 2.2 mm apart.

Calculate the electrostatic force between the two drops.

mass of each drop = 1.0×10^{-13} kg

(3)

.....

.....

.....

.....

.....

.....

Force between oil drops =



P 4 6 6 4 8 A 0 1 7 2 8

(e) With reference to the forces acting on the drops, explain what would happen to the oil drops if V is increased above 5000 V.

(3)

.....

.....

.....

.....

.....

.....

.....

.....

.....

.....

(Total for Question 17 = 13 marks)

DO NOT WRITE IN THIS AREA

DO NOT WRITE IN THIS AREA

DO NOT WRITE IN THIS AREA



DO NOT WRITE IN THIS AREA

DO NOT WRITE IN THIS AREA

DO NOT WRITE IN THIS AREA

BLANK PAGE



P 4 6 6 4 8 A 0 1 9 2 8

18 In his theory of special relativity, Einstein proposed that it is impossible for particles to travel faster than the speed of light.

In 1964 the physicist William Bertozzi performed an experiment to test Einstein's theory. Electrons were accelerated from rest through a potential difference (p.d.) and their kinetic energy was determined.

The electrons then travelled through a tube 8.4 m long and the time taken to travel this distance was measured. The speed of the electrons in the tube was then calculated.

The table shows results based on Bertozzi's experiment.

Kinetic energy of electron / 10^{-13} J	Speed of electron / 10^8 m s $^{-1}$
0.8	2.60
1.6	2.73
2.8	2.89
4.8	2.95
7.2	2.96

(a) Calculate the p.d. needed to accelerate an electron from rest if it gains a kinetic energy of 7.2×10^{-13} J.

(2)

p.d. =



DO NOT WRITE IN THIS AREA

DO NOT WRITE IN THIS AREA

DO NOT WRITE IN THIS AREA

(b) The results are plotted on the graph below.

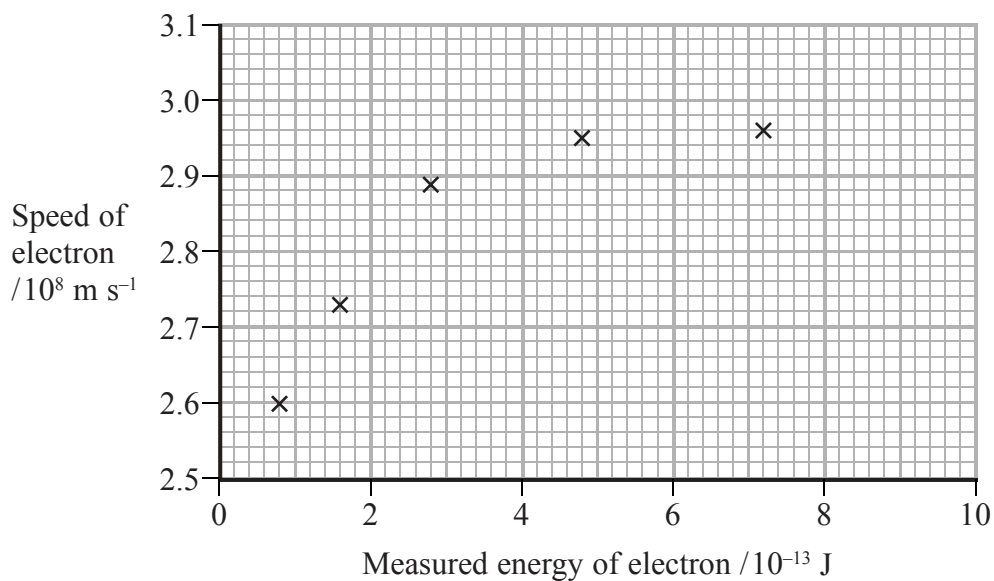

Use the graph to verify that Bertozzi's experiment supports Einstein's theory.

(2)

.....

.....

.....

.....

(c) A student uses the equation $E_k = \frac{1}{2}mv^2$ and information from the data at the back of this paper to calculate values for the kinetic energy of the electrons in this experiment. When he compares his correctly calculated values with the measured values in the table, they are **not** the same. Explain why.

(2)

.....

.....

.....

.....

.....



- (d) Bertozzi used an early type of linac to accelerate the electrons in his experiment. The diagram shows the essential structure of a modern linac.

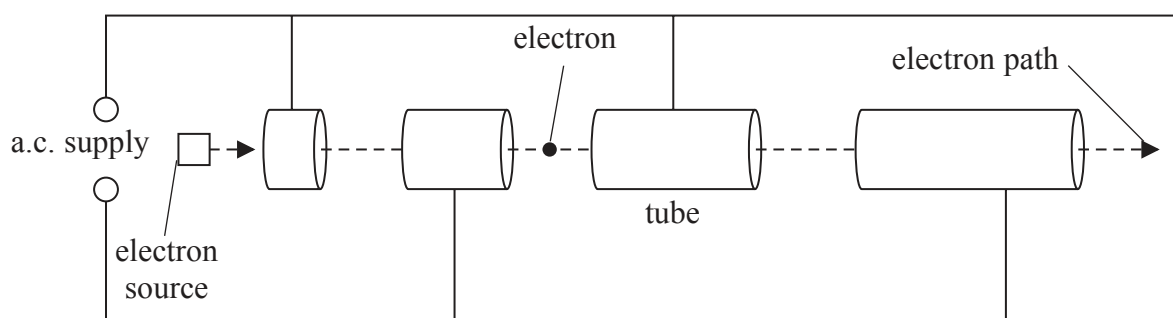

In the first part of the accelerator the drift tubes gradually increase in length, but at the end of the accelerator, the tubes are of the same length.

- (i) Explain why the tubes gradually increase in length in the first part of the accelerator. (2)

.....

.....

.....

.....

- (ii) State why the tubes are the same length at the end of the accelerator. (1)

.....

.....

(Total for Question 18 = 9 marks)

TOTAL FOR SECTION B = 70 MARKS

TOTAL FOR PAPER = 80 MARKS



List of data, formulae and relationships

Acceleration of free fall	$g = 9.81 \text{ m s}^{-2}$	(close to Earth's surface)
Boltzmann constant	$k = 1.38 \times 10^{-23} \text{ J K}^{-1}$	
Coulomb's law constant	$k = 1/4\pi\epsilon_0$ $= 8.99 \times 10^9 \text{ N m}^2 \text{ C}^{-2}$	
Electron charge	$e = -1.60 \times 10^{-19} \text{ C}$	
Electron mass	$m_e = 9.11 \times 10^{-31} \text{ kg}$	
Electronvolt	$1 \text{ eV} = 1.60 \times 10^{-19} \text{ J}$	
Gravitational constant	$G = 6.67 \times 10^{-11} \text{ N m}^2 \text{ kg}^{-2}$	
Gravitational field strength	$g = 9.81 \text{ N kg}^{-1}$	(close to Earth's surface)
Permittivity of free space	$\epsilon_0 = 8.85 \times 10^{-12} \text{ F m}^{-1}$	
Planck constant	$h = 6.63 \times 10^{-34} \text{ J s}$	
Proton mass	$m_p = 1.67 \times 10^{-27} \text{ kg}$	
Speed of light in a vacuum	$c = 3.00 \times 10^8 \text{ m s}^{-1}$	
Stefan-Boltzmann constant	$\sigma = 5.67 \times 10^{-8} \text{ W m}^{-2} \text{ K}^{-4}$	
Unified atomic mass unit	$u = 1.66 \times 10^{-27} \text{ kg}$	

Unit 1

Mechanics

Kinematic equations of motion	$v = u + at$ $s = ut + \frac{1}{2}at^2$ $v^2 = u^2 + 2as$
Forces	$\Sigma F = ma$ $g = F/m$ $W = mg$
Work and energy	$\Delta W = F\Delta s$ $E_k = \frac{1}{2}mv^2$ $\Delta E_{\text{grav}} = mg\Delta h$

Materials

Stokes' law	$F = 6\pi\eta rv$
Hooke's law	$F = k\Delta x$
Density	$\rho = m/V$
Pressure	$p = F/A$
Young modulus	$E = \sigma/\epsilon$ where Stress $\sigma = F/A$ Strain $\epsilon = \Delta x/x$
Elastic strain energy	$E_{\text{el}} = \frac{1}{2}F\Delta x$



Unit 2*Waves*Wave speed $v = f\lambda$ Refractive index ${}_1\mu_2 = \sin i / \sin r = v_1 / v_2$ *Electricity*Potential difference $V = W/Q$ Resistance $R = V/I$

Electrical power, energy and efficiency

$$P = VI$$

$$P = I^2R$$

$$P = V^2/R$$

$$W = VI t$$

$$\% \text{ efficiency} = \frac{\text{useful energy output}}{\text{total energy input}} \times 100$$

$$\% \text{ efficiency} = \frac{\text{useful power output}}{\text{total power input}} \times 100$$

Resistivity $R = \rho l/A$

Current

$$I = \Delta Q / \Delta t$$

$$I = nqvA$$
Resistors in series $R = R_1 + R_2 + R_3$ Resistors in parallel $\frac{1}{R} = \frac{1}{R_1} + \frac{1}{R_2} + \frac{1}{R_3}$ *Quantum physics*Photon model $E = hf$ Einstein's photoelectric equation $hf = \phi + \frac{1}{2}mv_{\max}^2$ 

Unit 4

Mechanics

Momentum	$p = mv$
Kinetic energy of a non-relativistic particle	$E_k = p^2/2m$
Motion in a circle	$v = \omega r$ $T = 2\pi/\omega$ $F = ma = mv^2/r$ $a = v^2/r$ $a = r\omega^2$

Fields

Coulomb's law	$F = kQ_1Q_2/r^2$ where $k = 1/4\pi\epsilon_0$
Electric field	$E = F/Q$ $E = kQ/r^2$ $E = V/d$
Capacitance	$C = Q/V$
Energy stored in capacitor	$W = \frac{1}{2}QV$
Capacitor discharge	$Q = Q_0 e^{-t/RC}$
In a magnetic field	$F = BIl \sin \theta$ $F = Bqv \sin \theta$ $r = p/BQ$
Faraday's and Lenz's Laws	$\epsilon = -d(N\phi)/dt$

Particle physics

Mass-energy	$\Delta E = c^2 \Delta m$
de Broglie wavelength	$\lambda = h/p$

DO NOT WRITE IN THIS AREA



DO NOT WRITE IN THIS AREA

DO NOT WRITE IN THIS AREA

DO NOT WRITE IN THIS AREA

BLANK PAGE



DO NOT WRITE IN THIS AREA

DO NOT WRITE IN THIS AREA

DO NOT WRITE IN THIS AREA

BLANK PAGE



P 4 6 6 4 8 A 0 2 7 2 8

DO NOT WRITE IN THIS AREA

DO NOT WRITE IN THIS AREA

DO NOT WRITE IN THIS AREA

BLANK PAGE

